

STRYKER RIB LX 250

The Stryker RIB LX 250 has a double aluminum hull with flat deck. Bow locker and EVA flooring are standard features on these beautiful boats.

SPECIFICATIONS

SIZE

- | | |
|---------------------|----------------|
| ○ Overall Length | 250cm or 8' 2" |
| ○ Inside Length | 157cm or 5' 1" |
| ○ Overall Width | 170cm or 5' 6" |
| ○ Inside Width | 79cm or 2' 6" |
| ○ Weight | 58kg or 128lbs |
| ○ Tube Diameter | 44cm or 1' 4" |
| ○ # of Air Chambers | 3 |
| ○ PVC Thickness | 0.9mm |

CAPACITY

- | | |
|---------------------|-----------------|
| ○ Max Load | 360kg or 793lbs |
| ○ Max # people | 3 |
| ○ Max Motor | 15 HP |
| ○ Max Motor Weigh | 60kg or 132lbs |
| ○ Transom Height | 15" |
| ○ Max Tube Pressure | 3.6 psi |

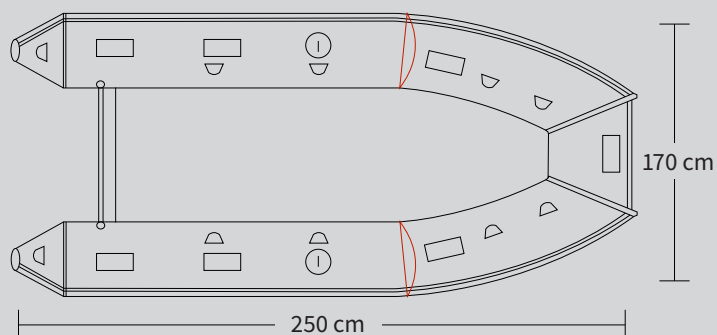



FEATURES

- Entirely Thermowelded Seams
- Integrated transom supports
- 2.5mm Aluminum hull
- 0.9mm Heytex PVC tube
- Stryker Shield™ Keel Strake
- Stryker Shield™ Under Tubes
- 2x oar holders on inner tube
- Anti Over-Inflation Safety Valve
- Reinforced Tube to Transom
- Stern tabs
- Exterior Water Redirecting Strake
- Handle @ Bow
- Tow Rope
- 2 Tow Rings on aluminum hull
- Bow locker (Fit 24L fuel tank)
- Removable seat with EVA
- Drain Valve
- Carry Handles
- Slider seat design
- Engine Mounting Plate
- Gas Tank Belt
-

INCLUDED IN BOX

- 1x Aluminum Bench Seat
- Aluminum Oars
- Foot Pump
- Repair Kit
- Attachable Fabric Oar Holders
-
-
-
-
-
-